

LOGISTICS GUIDE

Guidelines and procedures relating to deliveries made to Indeks Retail.

Version: 2.6
Modified: 01/03-2024
By: PWI

1. Introduction.....	3
2 Master data.	4
2.1 Product master data.	4
2.2 Packaging levels for trade units and logistic units	4
2.3 Identifiers – barcodes.	5
2.4 Example of a unique barcode for each packaging level:	6
2.5 Product information.	7
2.6 Dimensions.....	7
2.7 Weight.....	7
3 Packing and palletizing.....	8
3.1 Packing of pallets.	8
3.2 Packing of package.....	8
3.3 Packing in container.....	9
3.4 Replacements pallets.	9
3.5 Charges relating to package and palletized deliveries.	9
4 Goods reception	10
4.1 PASS on Point.....	10
4.2 Delivery note	10
4.3 Charges relating to delivery notes.	12
4.4 Goods receipt.	12
4.5 Control at delivery.....	13
4.6 Charges at delivery.....	13
4.7 Charges by hours.	14
5 Purchasing	14
5.1 Ordering of products.....	14
5.2 Order confirmations.....	14
5.3 Charges relating to order confirmations.....	14
5.4 Charges relating to delivery.	15
5.5 Charges relating to wrong terminal.....	15
6 Contact information and opening hours.....	16
6.1 Opening Indeks Retail - administration.....	16
6.2 Opening hours Indeks Retail - administration.....	16
6.3 Contact to the warehouse.....	16
6.4 Opening hours to the warehouse.	16
7. Quick guide for delivery.....	17

1. Introduction

The purpose of this Logistics Guide is to define the guidelines relating to delivery of goods to Indeks Retail. This Guide explains in detail how Indeks Retail requires deliveries, to ensure optimization and consistent flow through Indeks Retail's supply chain.

To ensure a successful implementation of these guidelines it is important that all supplier and sub-supplier are familiar with the instructions in this Guide.

This Logistics Guide is available on the Indeks Retail web site www.indeksRetail.dk, under the menu "Leverandører".

Indeks Retail continuously update this Logistics Guide and therefore it is important that you regularly check the website to ensure you have the latest version. The current version number can be found on the front page of the Logistics Guide.

This Logistics Guide intends to create the best conditions for the efficient flow of goods through our part of the supply chain and on to our customers.

For this reason, it has regrettably been necessary for Indeks Retail to implement financial penalties for suppliers who fail to comply with the guidelines.

The consequences for non-compliance with the guidelines are specified in the individual tariff sheets later in this Logistics Guide.

Of course, we hope that all our suppliers will consider this initiative as a benefit for us all.

If you have any questions relating to the requirements, please contact the Purchase department, see contact information under section 6.

Best regards,
Indeks Retail

Peter Wilstrup
Logistics Manager

2 Master data.

2.1 Product master data.

Trade between Indeks Retail and our suppliers is, to an increasing degree, based on structured information about products and their logistical attributes. This is required when we order and receive goods at our terminals and during further distribution to our customers. It is therefore essential that the product information we receive from our suppliers is accurate and complete.

Registration of new products must be made through our registration form in Excel sent upon request to the purchasing department.

New in the goods creation form is Dangerous goods, where the UN number must be provided. Goods with dangerous goods may not be delivered to the warehouse without prior approval from Indeks Retail.

2.2 Packaging levels for trade units and logistic units

Each set of master data belongs to at different packaging levels. The packaging levels are defined below.

Packaging level	Definition
Consumer unit/ Trade unit (The product)	<p>A consumer unit is the individual unit sold to the consumer.</p> <p>Example: A blue binder, a glue stick</p> <p>In this example, 1 unit must be entered on the registration form.</p>
Retail package (Inner package)/ logistic unit	<p>A Retail package can contain more consumer units and normally defines the level at which Indeks Retail trades with its customers. Indeks Retail orders products from its suppliers at this level.</p> <p>Example: 10 blue binders, 10 bags of indexes</p> <p>In this example, 10 units must be entered on the registration form.</p>
Wholesale package (Outer package)/ logistic unit	<p>A wholesale package is used to keep a quantity of Retail packages together, which, due to their size or fragility cannot otherwise be stacked.</p> <p>Example: A wholesale package with 48 Retail packages, each with 12 ballpoint pens (a total of 576 consumer units)</p> <p>In this example, 576 units must be entered on the registration form.</p>

2.3 Identifiers – barcodes.

Regardless of which packing level are being used, it must be possible to identify each package individually. A separate EAN-number¹ is therefore applied to each packing level.

The success of the EAN number is due in part to the fact that it is uniform and because the number can be determined from the barcode. During product registration, Indeks Retail will request the following EAN data:

Packaging level	Use	Number types
Consumer unit	Scanning, for example, at bookstore cash registers and communication via EDI.	EAN-13
Retail package	Indeks Retail Goods in.	EAN-13 or ITF-14
Wholesale package	Indeks Retail Goods in.	EAN-13 or GS1-128

Though all three packaging levels can be identified using EAN-13, the same barcode number may not be used. Each packaging unit must be assigned an individual EAN number.

Correct labelling is a prerequisite to be able to receive and manage pallets and packages in our warehouse.

All Retail packages and pallets must be marked with an EAN13 or TIF14 barcode.

This barcode must be placed on either the long or the short side of the pallet/package and must clearly identify what product it contains.

¹ For further information about the EAN standard, please refer to the GS1 website – www.gs1.org

Logistics Guide

2.4 Example of a unique barcode for each packaging level:

E.g. Relief A4 carton:

Packaging level	Product quantity	EAN-number	Barcode
Consumer unit.	1,00	EAN-13 5702518290076	 5 702518 290076
Retail package.	10,00	EAN-13 5702517290077 ITF-14 05702517290077	 5 702517 290077  05702517290077
Wholesale package or pallet.	90,00	EAN-13 5702516290078 GS1-128	 5 702516 290078  (01) 01234567890128 (15) 057072

2.5 Product information.

All packaging levels must at least contain the following information.

Packaging level	Definition
Consumer unit.	<ul style="list-style-type: none"> Barcode in numbers. Barcode for scanning.
Retail package.	<ul style="list-style-type: none"> Barcode in numbers. Barcode for scanning. Item number Item name. Number of pieces per Retail package.
Wholesale package.	<ul style="list-style-type: none"> Barcode in numbers. Barcode for scanning. Item number Item name. Number of pieces per Retail package. Gross weight.

2.6 Dimensions

In logistical terms, dimensions always apply to the consumer unit. If a consumer unit is a point of a sales display or a quarter-pallet display unit, the dimensions of that unit must be provided.

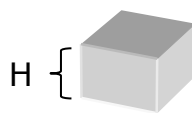
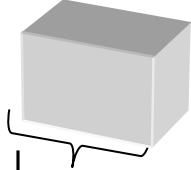
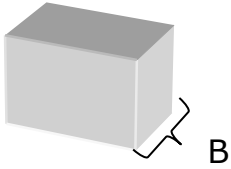
Dimension	Definition
Height (mm)	<p>The height is always measured along the vertical side of the Retail package, when placed on the pallet. This always applies, even if the consumer unit inside the package will be positioned differently on the pallet than in its unpacked state.</p> <p>The height forms part of the calculation of the pallet's overall height and the Retail package volume. .</p> 
Length (mm)	<p>The length is measured along the longest horizontal side of the Retail package, when placed on the pallet.</p> <p>The length forms part of the calculation of the Retail package volume.</p> 
Width (mm)	<p>The width is measured along the shortest horizontal side of the Retail package, when placed on the pallet.</p> <p>The width forms part of the calculation of the Retail package volume</p> 

2.7 Weight

In logistical terms, weight always applies to the consumer unit.

Weight	Definition
Gross weight	The gross weight is the weight of the consumer unit including packaging material and transport packaging. The Euro pallet is also included in the weight calculation.
Net weight	The net weight is the weight of the consumer unit excluding all packaging material and pallet.

3 Packing and palletizing.

3.1 Packing of pallets.

Packages must be secured onto a pallet using outer wrapping, such as foil. All goods must be secured in a way that allows for transportation without risk of falling off or collapsing.

- Goods must never extend outside the dimensions of the pallet base.
- Each item number must be delivered separately on a pallet.

Please note that if multiple item numbers are stacked on top of each other, an empty pallet must be placed between each product. If the order quantity of a product fills less than one pallet layer, then multiple products can be loaded onto the same pallet without requiring a separator pallet between each item number. A pallet loaded in this way must be clearly marked **MIX**.

Delivery height and weight limits:

	Maximum total height incl. Euro pallet and goods.	Maximum total weight incl. EUR pallet and goods.
1/1 pallet*	148 cm	1,000 kg

* The indicated pallet height is advisory and matches the storage rack dimensions used by Indeks Retail. If the product type, Retail package weight, packaging strength and ergonomics justifies it, higher pallets are accepted if the supplier can prove that certain conditions are met. Deviations can only take place by prior arrangement with Indeks Retail.

Goods are only accepted on approved EUR pallets. If an order is delivered on unauthorized pallets including disposable pallets, Indeks Retail reserves the right to invoice the supplier for repackaging to approved EUR pallets.

Deviations may only take place after prior agreement with Indeks Retail.

All goods must be wrapped to withstand typical handling and transportation conditions. Every effort must be made to ensure that the base of each Retail package has a modular dimension equivalent to 60x40 or 30x40.

Maximum weight per Retail package should not exceed 15 kg (in accordance with The Danish Working Environment Authority Guidelines D.3.1 "Løft, træk og skub" - available only in Danish).

3.2 Packing of package.

All goods must be wrapped to withstand typical handling and transportation conditions. Every effort must be made to ensure that the base of each Retail package has a modular dimension equivalent to 60x40 or 30x40.

Maximum weight per Retail package should not exceed 15 kg (in accordance with The Danish Working Environment Authority Guidelines D.3.1 "Løft, træk og skub" - available only in Danish).

3.3 Packing in container

All parcels must be packed in such a way that the boxes do not slip or collapse in the container. If more item numbers are packed in the same container, they must be packed so that all parcels lie together.

Maximum weight per package should not exceed 15 kg. (With reference to AT instructions D.3.1 "Lift, pull and push").

On delivery, parcels for Indeks Retail must be placed closest to the door, so that the warehouse can easily access the goods.

If there are goods for other customers before goods for Indeks Retail, the warehouse can reject the delivery and the supplier must arrange for a new delivery at no extra cost. If the warehouse has time, they can by agreement, alternatively offer emptying/reloading at the supplier's expense.

If the goods have slipped during transport and the warehouse assesses that the goods may have been damaged and or that the goods are mixed up in the container, the warehouse may reject the delivery and the supplier must arrange for a new delivery at no extra cost.

3.4 Replacements pallets.

Indeks Retail and their warehouse do not work with pallet accounts. This means that if a supplier wishes to get EUR pallet returned, this should be done at the time of delivery.

It is the supplier's responsibility to ask for replacement pallets at the warehouse, and if it is not done at delivery, the supplier loses the right to receive replacements pallets later.

Indeks Retail only replaces approved EUR pallets that are intact, se section 3.1.

3.5 Charges relating to package and palletized deliveries.

Infringement	Comment	DKK excl. VAT
Max. pallet height exceeds 148 cm incl. pallet	Without prior agreement with Indeks Retail	2.500 per order + DK 390, - pr. hour
More than one item number per pallet.	<ul style="list-style-type: none"> Pallet is not clearly marked: MIX Pallet. Items are not packed together. 	500 per order + DK 390, - pr. hour
More than one item number per Retail / Wholesale package.	<ul style="list-style-type: none"> Package is not clearly marked: MIX Package. Items are not packed together. 	500 per order + DK 390, - pr. hour
Delivery made on non-approved pallet.	<ul style="list-style-type: none"> Non-approved EUR pallet without prior agreement with Indeks Retail 	2.500 per order + DK 390, - pr. Hour
Parcels in container not packed together	<ul style="list-style-type: none"> Parcels are mixed with other parcels in container. 	2.500 per order + DK 390, - pr. Hour

4 Goods reception

4.1 PASS on Point

The supplier is responsible for booking all deliveries in DSV's PASS on Point system.

The supplier must register himself for PASS on Point via the following link:

<https://dsveurope.passonpoint.com/>

Guide to creation and booking can be found on Indeks Retail's website together with this Logistics guide.

When booking, the supplier must state the number of pallets / parcels and specify at least one PO number.

When DSV has confirmed the booking, the supplier receives an email confirmation with a password.

If the delivery date or time changes, the supplier must update PASS on Point with the expected delivery date and time and inform Supply Chain about the delay.

If the delivery is not booked via PASS on Point, the driver will not have access to DSV's warehouse.

If the supplier has not booked access through PASS on Point and or arrives on a different date than the email confirmation, DSV is entitled to reject the carrier if DSV does not have time and resources to receive the shipment. In these cases, the supplier must book new time through PASS on Point and the supplier is not entitled to charge extra payment for a new delivery.

4.2 Delivery note

Each delivery must be accompanied by a delivery note that corresponds to the physical goods delivery.

The delivery note must be in paper form and inserted into a plastic pocket and placed on the short side of the pallet og package. Stick-on pallet notes are not at a delivery note.

A delivery note must always accompany a goods delivery and must contain the following information:

- Indeks Retail order number.
- Number of pieces per consumer unit.
- Supplier item number or/and EAN barcode.
- Item name.
- Item number.
- Delivery address.
- Delivery date.

Ordered goods must be delivered free of charge at Indeks Retail's terminals.

Goods are only received on approved EUR pallets. The driver must unload the goods himself and place them in the goods reception according to instructions from the goods reception staff.

Logistics Guide

Example of a delivery note.

Følgeseddel									
Leveres til: 166485 SYSTEM TRANSPORT A/S INDEKS RETAIL A/S PORT 48-49 PORT 48-49 TRANSPORTCENTERALLÉ 19-21 7400 HERNING DENMARK			Kundenr.: 170966 INDEKS RETAIL A/S HORSENS MOSSVEJ 2 8700 HORSENS DENMARK						
Side 1 / 1									
Deres reference	244134	Ordredato	04.01.2024	Loading Date	11.01.2024	Ønsket leveringsdato	15.01.2024	Kundenr.	170966
Ordretype	↳ Outbn. Delivery	Betalr	170966	↳ Ordrenr.	13732945	Deres leverandømr.		Leveringsnr.	92531394
Artikel	Pos. nr.	EAN / Deres art.nr.	Pos. nr.	Beskrivelse	EDI pos	Kartoner	Mængde		
6426515	260	5702017416953	2800	10325 Alpehytte		10	20		
6379254	20	5702017153636	300	10967 Politomotorcykel		10	40		
6426533	60	5702017417011	800	10986 Familiehus på hjul		10	30		
6426553	50	5702017417714	700	10993 3-i-1-træstophus		2	6		
6426573	170	5702017417721	1900	21060 Himejl-borgen		5	5		
6425582	80	5702017415154	1000	21240 Sumpeventyret		4	16		
6425584	90	5702017415161	1100	21241 Blhytten		2	12		
6420637	100	5702017399461	1200	21243 De frose tinder		2	10		
6425588	110	5702017415796	1300	21244 Sværd-forposten		29	87		
6371102	40	5702017117461	500	31124 Superrobot		10	40		
6425608	160	5702017415871	1800	31134 Rumpfærge		10	40		
6470624	270	5702017585116	2900	31149 Blomster i vandkande		4	16		
6425555	190	5702017412849	2100	41725 Strandbuggy-sjov		2	8		
6425662	180	5702017415215	2000	41736 Havdyrsinternat		3	9		
6420673	140	5702017400082	1600	42148 Pistemaskine		5	20		
6425760	130	5702017424736	1500	42151 Bugatti Bolide		10	30		
6427562	70	5702017424781	900	43211 Auroras slot		4	16		
6470730	250	5702017584898	2700	43238 Elsas Frost-palads		5	15		
6379605	30	5702017161914	400	60316 Politistation		10	30		
6425842	200	5702017416366	2200	60376 Polarforsker-snescooter		2	8		
6212630	10	5702016110319	100	71043 Hogwarts™-slottet		4	4		
6427653	220	5702017419268	2400	71456 Fru Castillos skildpaddevogn		2	10		
6425932	210	5702017413075	2300	71792 Soras forvandlings-mech-motorcykel		2	8		
6427675	150	5702017421292	1700	75345 Battle Pack med klonsoldater fra 501. legion		4	16		
6440292	230	5702017462820	2500	75368 Darth Vader™-kamprobot		4	16		
6440294	240	5702017462837	2600	75369 Boba Fett™-kamprobot		4	16		
6470417	290	5702017584317	3300	75372 Battle Pack med klonsoldater og kampdrolder		6	48		
6426026	120	5702017424217	1400	76917 2 Fast 2 Furious Nissan Skyline GT-R (R34)		5	20		
6465043	280	5702017567150	3200	76963 Dinosaurunge-internat		4	16		
Transportør		Bruttovægt KG	455,487	Volumen M3	4,345	Antal paller sendt	6	Antal kartoner sendt	174
Leveringsbetingelser		DAP Heming							

4.3 Charges relating to delivery notes.

Infringement	Comment	DKK excl. VAT
Delivery note must always follow the goods.		1000, - per order.
Delivery note does not contain all information.	Must at least contain: <ul style="list-style-type: none"> • Quantity delivered. • Supplier item number og Ean barcode. • Product description. • Indeks Retail order number. • Delivery address. • Delivery date. 	1000, - per order.
Delivery note is not located at the end of the pallet (one of the pallet's short sides).	Delivery note is missing.	1000, - per order.

4.4 Goods receipt.

Upon receipt, the warehouse acknowledges the quantity of pallets received. However, reservations are made regarding the number of inner parcels and the number of pieces on the pallets and for nonvisible damage.

A valid receipt consists of a signature/initial of the receiving warehouse employee.

Indeks Retail pays for the quantity of goods that the warehouse registers upon goods receipt.

If there are defects or deficiencies in the goods delivered by the supplier, the supplier is obliged to take back the defective or deficient quantity of goods for credit or exchange. This after further agreement with the Supply Chain department at Indeks Retail.

If an item is received without a barcode label or with an incorrect barcode label in relation to the stated barcode in the item creation form, and that the barcode in the item creation form is the correct one, Indeks Retail reserves the right to, without prior agreement with the supplier, affix new barcode labels at the supplier's expense in accordance with applicable rates.

Indeks Retail subsequently and as soon as possible contacts the supplier with photo documentation of the fault and provides the expected cost for rectifying the fault.

Logistics Guide

4.5 Control at delivery.

Receipt control Pallets.	<p>The following control is conducted upon receipt, to confirm the accuracy of the supplied information:</p> <ul style="list-style-type: none"> • Retail packages per pallet layer * pallet layers = Number of Retail packages per Euro pallet. • Number of pieces per Retail package * number of Retail packages = Number of pieces per EUR-pallet. (Only 1 Retail package is checked and counted. We assume that all Retail packages are packed with the same number of items. • Correct barcode for all 3 Packaging levels. • Product information. • Delivery note including the above information.
Receipt control Package.	<p>The following control is conducted upon receipt, to confirm the accuracy of the supplied information:</p> <ul style="list-style-type: none"> • Number of Retail packages per delivery. • Number of pieces per Retail package * number of Retail packages = Number of pieces per delivery. (Only 1 Retail package is checked and counted. We assume that all Retail packages are packed with the same number of items. • Correct barcode for all 3 Packaging levels. • Product information. • Delivery note including the above information.

4.6 Charges at delivery.

Each product must contain at least the following information.

Infringement	Comment	DKK excl. VAT
The product does not include the following consumer unit information:	<ul style="list-style-type: none"> • Consumer unit barcode for scanning. • Consumer unit barcode in numbers. 	2.500 per item number + DK 390, - pr. hour
Product information on the Retail package does not contain one of the following:	<ul style="list-style-type: none"> • Retail barcode for scanning. • Retail barcode in numbers. • Item number and name. • Number of pieces per Retail package. 	2.500 per delivery + DK 390, - pr. hour
Product information on the wholesale package does not contain one of the following:	<ul style="list-style-type: none"> • Wholesale barcode for scanning. • Wholesale barcode in numbers. • Item number and name. • Gross weight. • Number of pieces per wholesale package. 	2.500 per delivery + DK 390, - pr. hour

4.7 Charges by hours.

Indeks Retail has unfortunately been compelled to implement financial penalties for suppliers who do not comply with the guidelines for proper packaging, palletizing, item information and barcode labelling. The prices below are ex. VAT. In addition to the prices below, additional cost may apply for repackaging or relabelling at a charge of DKK 390, - per hours.

5 Purchasing

5.1 Ordering of products

Indeks Retail will send purchase orders via e-mail or electronic transfer (EDI). EDI is the preferred method. If the supplier has the capability for EDI, but does not currently have an EDI agreement with Indeks Retail, please contact Indeks Retail IT-department by email serviceit@i-r.dk.

5.2 Order confirmations

The supplier must confirm each purchase order within five working days from order date, according to the order confirmation.

By “working day” means all days of the week except Saturdays, Sundays, and National Holidays in the country in which the order is to be delivered.

If the delivery date is earlier than the above date for confirmation of the order, the supplier must confirm the order within 24 hours prior to delivery to Indeks Retail.

If a purchase order cannot be fulfilled in terms of quantity, quality, delivery date or prices, the supplier must immediately contact Supply Chain department at Indeks Retail. See contact information under section 7.

The supplier must immediately contact Indeks Retail if changes occur in the product master data.

5.3 Charges relating to order confirmations.

Infringement	Comment	DKK excl. VAT
Order confirmed later than five working days, or later than 24 hours if the confirmed delivery date is prior to the deadline of 5 days.	After receipt of requisition.	2.500 per order.

Logistics Guide

5.4 Charges relating to delivery.

Infringement	Comment	DKK excl. VAT
Too late or prompt delivery according to confirmed delivery.	Without prior agreement with Indeks Retail.	2.500 per order.
In case of delay, we will assess whether the delay means lost profits and whether additional cost is required for extra handling and shipment to our stores. These costs accruing to the supplier.	In case of delayed delivery, Indeks retail can provide urgent expedition and shipment to our stores at the supplier's expense. The price is for 1 order with 1 product line. If more product lines, please contact the Supply Department.	65 per order with 1 product line. (if more than 1 product line, the prices can change).

5.5 Charges relating to wrong terminal.

Infringement	Comment	DKK excl. VAT
Delivering to the wrong terminal	Delivering to a terminal other than that specified by the Purchasing Department.	2,500 per delivery + cost for transportation.

6 Contact information and opening hours.

6.1 Opening Indeks Retail - administration.

<u>Group</u>	<u>E-mail</u>	<u>Telephone</u>
Reception		7675 2000
Purchase, books	servicebog@i-r.dk	7675 2097
Purchase, play	serviceleg@i-r.dk	7675 1219.
Purchase, trend, office, games	servicekontortrend@i-r.dk	7675 2060
Supply Chain	servicesupplychain@i-r.dk	7675 2063
Account Payable	serviceOko@i-r.dk	7675 2047
Indeks Retail EDI	serviceit@i-r.dk	

6.2 Opening hours Indeks Retail - administration.

The Administration switchboard and personnel are available via telephone and e-mail:

Monday to Thursday 08:00–16:00

Friday 08:00–15:30

Closed on public holidays.

6.3 Contact to the warehouse.

DSV Solution A/S

C/O Indeks Retail

Mossvej 27

Port 711-715

8700 Horsens.

Denmark

6.4 Opening hours to the warehouse.

Monday to Thursday 07:00–15:00

Friday 07:00–14:00

Closed on public holidays.

7. Quick guide for delivery.

This Quick guide highlights key areas that must be met for delivery to take place without errors and delays.

- Is the purchase order confirmed with a confirmed delivery date?
- Is the delivery booked in PASS on Point?
- Do all physical barcodes (sales unit, retail and-wholesale package) match with the barcodes stated in the item creation form?
- Are the number of pcs. the same according to the purchase order?
- Are the number of pcs. the same according to the delivery note?
- Are the goods correctly packed in packages and on pallets?
- Are delivery notes in plastic pockets included on pallets and parcels?
- Are the goods clearly divided and marked with MIX?
- Are the goods packed on approved EU pallets?